

McDonald's Common Electric Enhancement Instructions

IMPORTANT: Before beginning this work, ensure the coverage acknowledgement and prework checklist have been completed and signed by the owner/store manager or their representative.

KIT CONTENTS

Single Fryer Wiring Restraint Kit 826-1513		
Part No.	Quantity	Description
106-0572	1	Support Bracket, LT
106-0573	1	Support Bracket, RT
802-1983	1	Tools/Parts Notice
807-3301	3	Butt splice
809-0117	12	Screw, 10-32 x 3/8
809-0256	12	Nut, 10-32 Keps Hex
809-0361	2	Screw, #8 x 1/2 Hex
809-0434	5	Screw, #10 x 3/8 Hex
809-0810	2	Nylon Wire Clamp
811-0966	1 ft	Heat shrink tubing
816-0531	4	Spiral-cut Wrap
819-5731	1	Instructions
826-1385	1	Ty-Wraps (Pkg of 25)
900-9582	1	Brace, Rear
900-9585	1	Guard, Spring
910-9586	2	Shroud, Element
809-0518	2	Screw, 8-32 x 3/8 Hex

2-Fryer Battery Wiring Restraint Kit 826-1514		
Part No.	Quantity	Description
106-0572	2	Support Bracket, LT
106-0573	2	Support Bracket, RT
802-1983	1	Tools/Parts Notice
807-3301	6	Butt splice
809-0117	24	Screw, 10-32 x 3/8
809-0256	24	Nut, 10-32 Keps Hex
809-0361	4	Screw, #8 x 1/2 Hex
809-0434	10	Screw, 10 x 3/8, hex
809-0810	4	Nylon Wire Clamp
811-0966	2 ft	Heat shrink tubing
816-0531	8	Spiral-cut Wrap
819-5731	1	Instructions
826-1385	2	Ty-Wraps (Pkg of 25)
900-9585	2	Guard, Spring
200-0084	1	Brace, Rear
910-9586	4	Shroud, Element
809-0518	2	Screw, 8-32 x 3/8 Hex

3-Fryer Battery Wiring Restraint Kit 826-1515		
Part No.	Quantity	Description
106-0572	3	Support Bracket, LT
106-0573	3	Support Bracket, RT
802-1983	1	Tools/Parts Notice
807-3301	9	Butt splice
809-0117	36	Screw, 10-32 x 3/8
809-0256	36	Nut, 10-32 Keps Hex
809-0361	6	Screw, #8 x 1/2 Hex
809-0434	15	Screw, 10 x 3/8, hex
809-0810	6	Nylon Wire Clamp
811-0966	3 ft	Heat shrink tubing
816-0531	12	Spiral-cut Wrap
819-5731	1	Instructions
826-1385	3	Ty-Wraps (Pkg of 25)
200-0085	1	Brace, Rear
900-9585	3	Guard, Spring
910-9586	6	Shroud, Element
809-0518	2	Screw, 8-32 x 3/8 Hex

4-Fryer Battery Wiring Restraint Kit 826-1516		
Part No.	Quantity	Description
106-0572	4	Support Bracket, LT
106-0573	4	Support Bracket, RT
802-1983	1	Tools/Parts Notice
807-3301	12	Butt splice
809-0117	48	Screw, 10-32 x 3/8
809-0256	48	Nut, 10-32 Keps Hex
809-0361	8	Screw, #8 x 1/2 Hex
809-0434	20	Screw, 10 x 3/8, hex
809-0810	8	Nylon Wire Clamp
811-0966	4 ft	Heat shrink tubing
816-0531	16	Spiral-cut Wrap
819-5731	1	Instructions
826-1385	4	Ty-Wraps (Pkg of 25)
900-9585	4	Guard, Spring
200-0084	2	Brace, Rear
910-9586	8	Shroud, Element
809-0518	2	Screw, 8-32 x 3/8 Hex

NOTE: A 5-fryer battery requires one 826-1514 and one 826-1515 kit.

INSTALLATION INSTRUCTIONS FOR HOOD BLANK-OFF PLATES

1. Disconnect the fryer from the electrical power supply, pull the fryer from the hood, and remove the baffle screens (Fig. 1) to expose the vent opening at the rear of the hood.

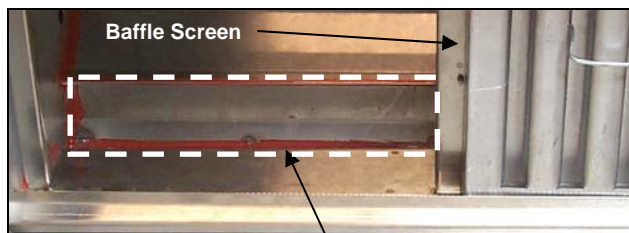

Fig. 1: The blank-off plates fit into this area of the hood and prevent excessive draft from being created at the back of electric fryers.

2. Remove excess oil from the hood and position a blank-off plate, with the spring-loaded clip on the lower side, over the opening at the rear of the hood as shown in Fig. 2. Press in on the spring-loaded clip and maneuver the plate until the clip catches behind the lower rim of the opening.

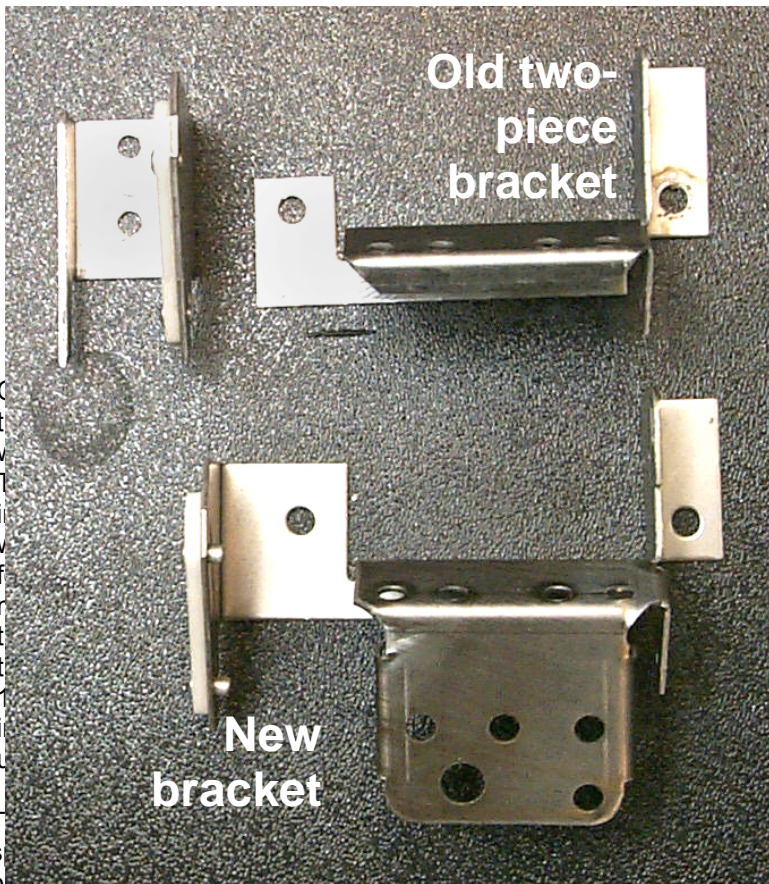

Fig. 2: Position a blank-off plate in the hood as shown and secure in place using its spring-loaded clip.

3. Release the spring and make any final adjustments needed to position the plate over the opening (see Fig. 3). In some hoods, the plates may rest at a different angle than shown in photos.
4. In a similar manner, install additional plates, one overlapping another, until the opening is completely sealed (i.e., two plates are required for a 2-Fryer battery, three for a 3-fryer battery, four for a 4-fryer battery, etc.).
5. When all required plates have been installed, replace the baffle screens.
6. If a Garland Electric grill is present, follow steps 1-5 to install blank-off plates over the grill. It is not necessary to disconnect power or pull the grill from under the hood for the installation. Note model and serial number of the grill on the work order/invoice.



Fig. 3: First blank-off plate in a 2-fryer hood shown in final position. A second plate, needed to complete the installation, will overlap the first in the center of the hood.



of Retrofit Required.

Electric Fryers manufactured from 1996 ('97 in the field. Newer fryers and previously the photos below to determine the amount new elsewhere, have hi-limits on the tilt-plates 11-14.

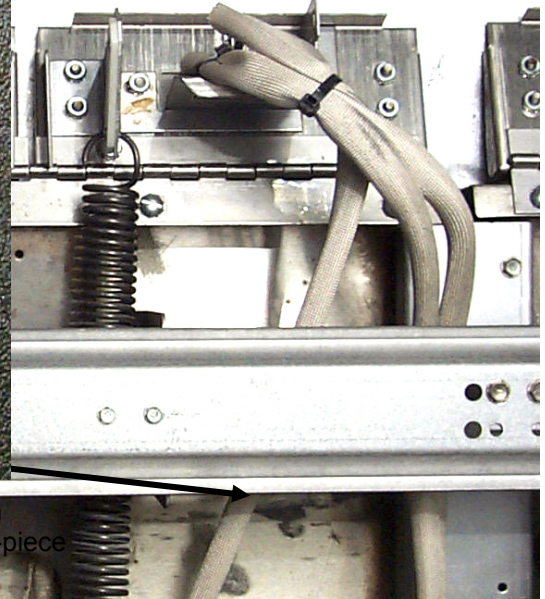

Figure 1: Newer fryers will get a new element support bracket which provides new tie-down points for the element wires. The old two-piece bracket is shown at the top of the photo.

Element wires on newer fryers are routed as shown and lack the fabric covering.

Figure 1: A fryer exhibiting these features will require a complete retrofit.

A new rear brace has an extended spring shroud attached.

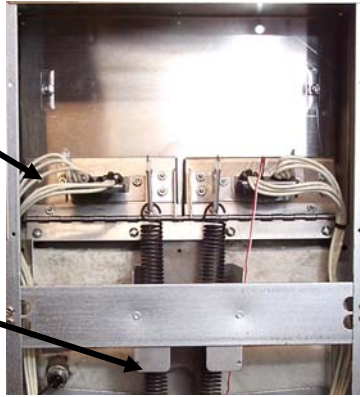

Figure 2: Newer fryers show these features and require only a tilt-plate bracket replacement, wire rerouting and spiral wrap.

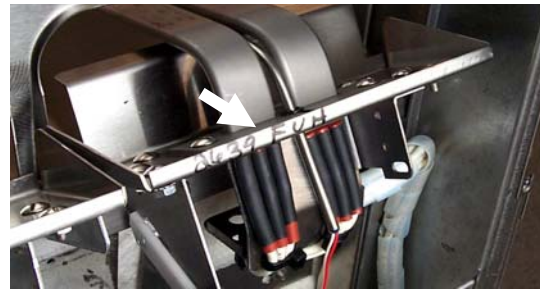

Figure 3: A shroud is provided in the retrofit kit and should be added if the raised edge (shown with the arrow) is absent from the fryer being retrofitted. A tilt-plate without the needed shroud is shown below.



Figure 3A

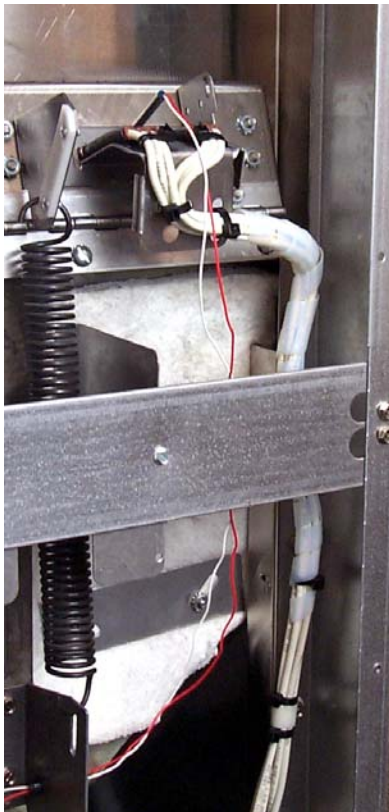

Figure 5: A reworked fryer is shown at left. The element wires are attached to the new element support bracket in four places with wire ties. The element wires are also encased in a spiral wrap from the point they leave the bracket to below the level of the hi-limit. A drawing of the wire routing and placement of the spiral wrap is shown on page 10.

1. Disconnect the unit from the electric power source.
2. Remove all back panels.
3. Remove the tilt-housing cover and rear brace; retain the screws.
4. Use shears to cut all sheathing and tie wraps from the element, probe, and hi-limit wires (see Fig. 6).
5. Lift the elements and rest them on the vat covers. Detach the element springs.
6. Clean grease and oil from around the tilt plate
7. Remove the existing element support brackets from the tilt housing and replace them with the brackets provided in the kit. See Fig. 7,8. Some fryers will have the hi-limit attached to the bracket. See pages 11-14 for special instructions for such units. **Note:** Oil encrusted nuts can be loosened by spinning them counterclockwise with a cordless electric driver before attempting to back them off. Screws stuck in a nut can be removed by drilling out the portion of the screw exposed in the nut and breaking off the nut. Use a 1/8-in or 3.2 mm drill bit.
8. Inspect the element wires for cuts, nicks, and scrapes. If the insulation is badly scuffed but the conductor (wire) is intact and serviceable, disconnect the lead and repair the damaged area by covering it with heat-shrink tubing. If the conductor is damaged, cut out the damaged section and use one of the butt splices provided with the kit to reconnect the wire. **See notes on page 8 on repairing element wires.**
9. Secure the element wires to the element support bracket with four wire ties as shown at right and use the Go-No-Go gauge provided in the training session to ensure the element wires are properly routed away from the bracket as shown in Fig. 8. Correct wire routing as necessary to clear gauge as shown.

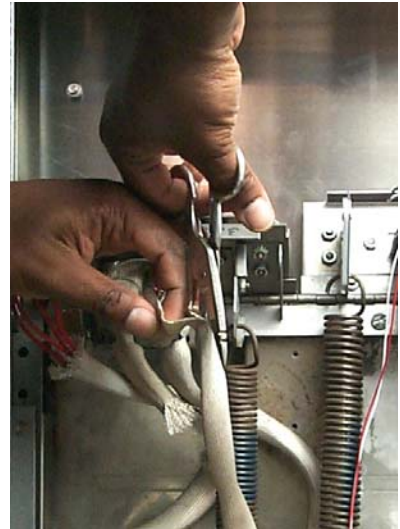

Figure 6: Cut all sheathing from the element wires.

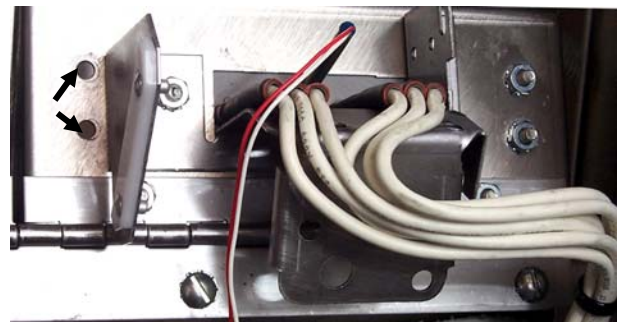

Figure 7: The new element support bracket includes the spring slide hardware. Remove and discard the old slide bracket. Reinstall the screws and nuts to fill the holes in the tilt plate on units with a shroud formed on the tilt plate. See arrows above. The holes are used to mount a shroud on older units. See Fig. 9.

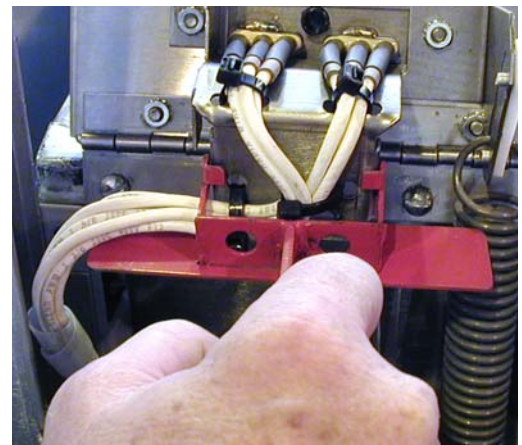

Figure 8: Place the provided gauge on the bracket and ensure the element wires have a sufficient loop to clear the gauge as shown. Correct routing as necessary.

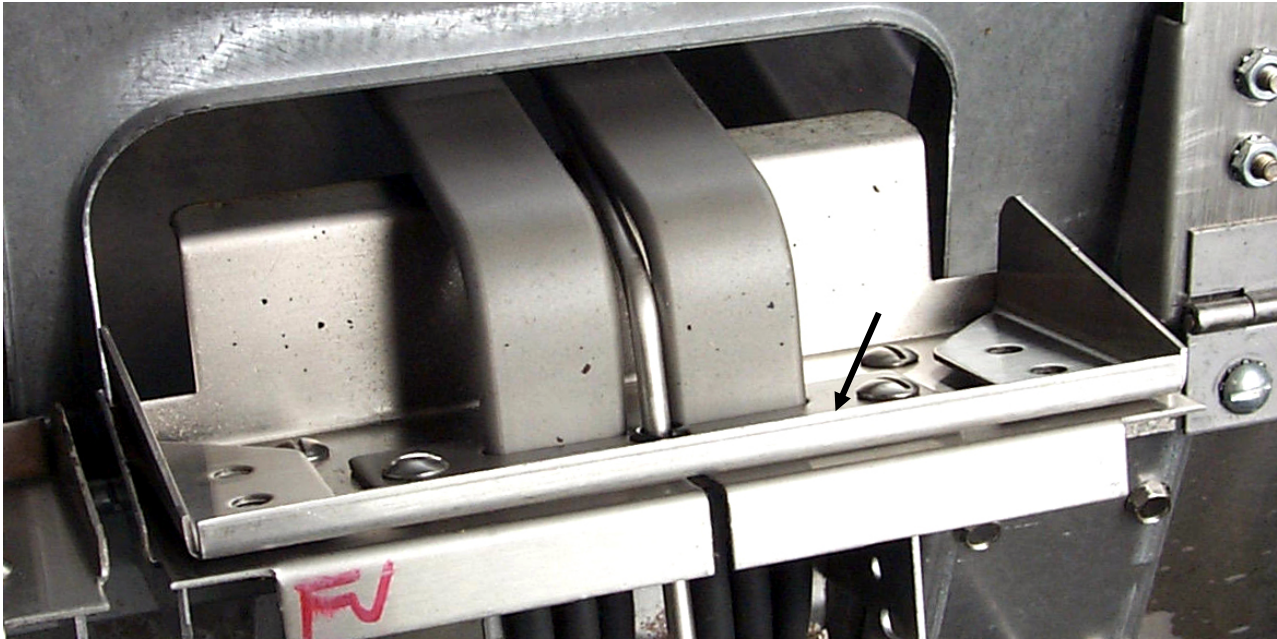

Figure 9: Attach the provided shroud (shown above) to the tilt assembly if the top edge it provides (see arrow) is absent from the existing assembly. See also Figure 2.

Notes on examining element wires

NOTE 1: If the break is on the element support bracket, **DO NOT** use a butt splice. Replace the element.

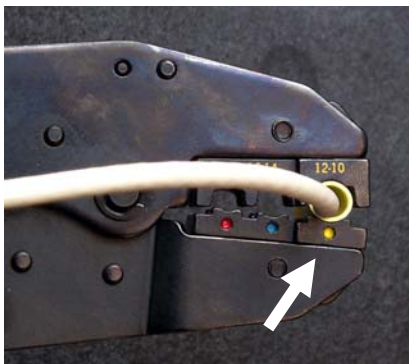

Figure 10: The end of the butt splice being crimped should be aligned with the yellow dot in the jaw and flush with the surface of the jaw.

NOTE 2: Stripping for the butt splices should be $5/16\text{-inch} \pm 1/32\text{-inch}$.

NOTE 3: It is mandatory that an Aven or Paladin crimping tool be used to install the butt splices. The Frymaster P/N for the tool is 815-0951.

NOTE 4: The element wire must be seated fully in the butt splice before crimping. The end being crimped must be aligned with the yellow dot in the jaws of the pliers. Apply pressure until the ratcheting ceases and there is an audible click. The jaws will release. See Fig. 10

NOTE 4: It is not necessary to use heat-shrink tubing over the butt splices.

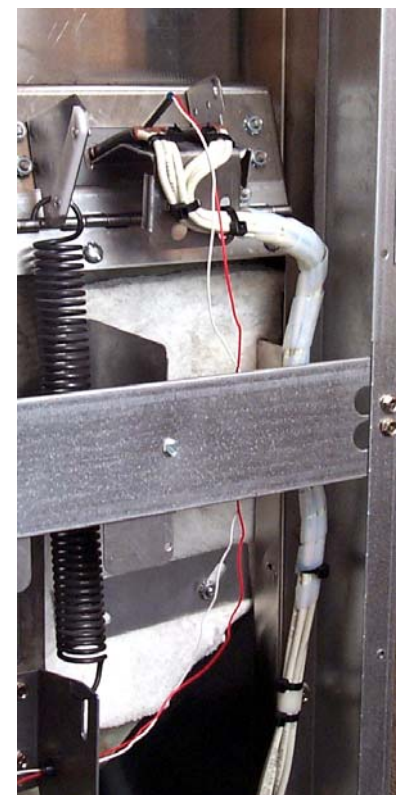

Figure 11: Route the element wires as shown and cover with spiral wrap from the bracket's edge to below the hi-limit. See wire-routing diagram on page 10.

10. On the element support bracket, a split bushing (817-1025) surrounds the probe. A plug (816-0480) fills that port if the probe is not present. Ensure the split bushing and plugs are in place. Replace if damaged or missing. Attach the element shroud, if needed, to the tilt-plate as shown in Figures 3 & 9.

11. Re-attach element springs and lower the elements into the frypot.

Note: For non-McDonald's fryers with rear oil return, lift element up to lock position and ensure wires do not touch the oil return. If wires touch, install power shower and bend the nipple until wires clear.

12. Place spiral wrap around the element wires to protect them from chafing (see Fig. 8, 11, 14). Ensure the wrap covers the element wires from the edge of the new bracket to below the level of the hi-limit. Attach a wire tie below the bottom edge of the spiral wrap to ensure it stays in place. See illustration on page 10.

13. Route the wires as shown in Fig. 11 and 14. Ensure the wires cannot touch the back of the fryer when the tilt-plate is moved. Also, ensure that the probe wires are not bundled with the element wires (see Fig. 11).

14. Route the lower portion of the element wires out of the way of the back panel. Use wire ties to secure as required. See Fig. 14. Suspend the C6 connector from the spring hanger with a wire tie. See Fig. 13. Ensure the probe wires are not tight and do not rub against sharp edges. Also, ensure they are clear of the element springs.

15. Attach the spring guard(s) to the new rear brace using the screws provided in the kit. **NOTE:** The rear brace in early-model fryers is located higher in the cabinet than the brace in later model fryers. If installing the guard(s) in an early-model fryer, use the upper set of holes; in later model fryers, use the lower set of holes (see Fig. 12). An improperly mounted guard on a high-mounted brace will prevent the elements from tilting. Install the rear brace, spring guard assembly.

16. *If the fryer has tilt plate-mounted hi-limits, see special instructions for wiring harness replacement on pages 11-14.*

17. Return power to unit and ensure proper operation before reinstalling back panels.

18. Install back panels and tilt housing cover and return to service.

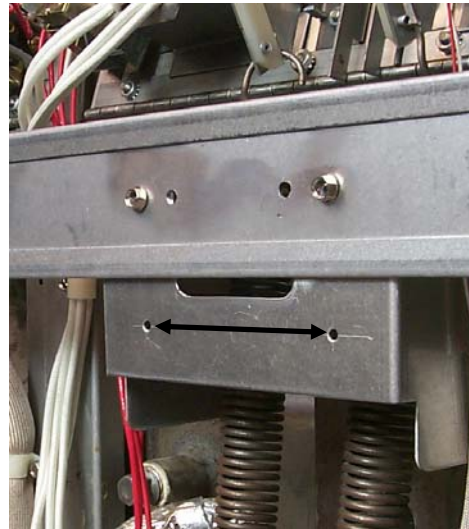

Fig. 12: Attach the new spring guard, which covers the element springs, to the new rear brace, then install the assembly into the fryer. The guard prevents wiring from being pinched in the springs. Use lower holes (arrows) to mount guard on later model fryers.

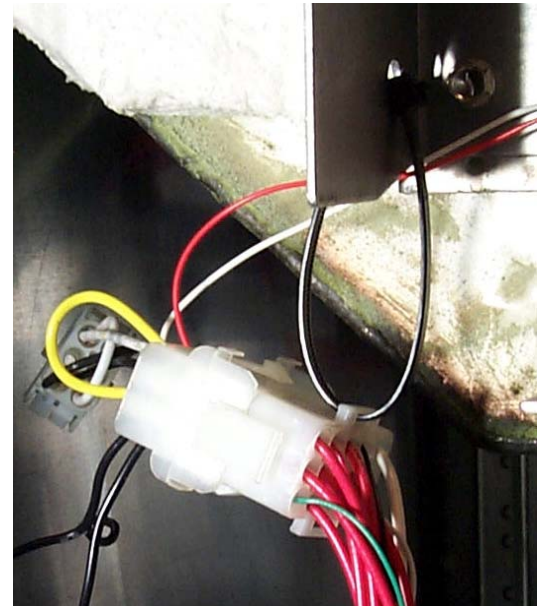
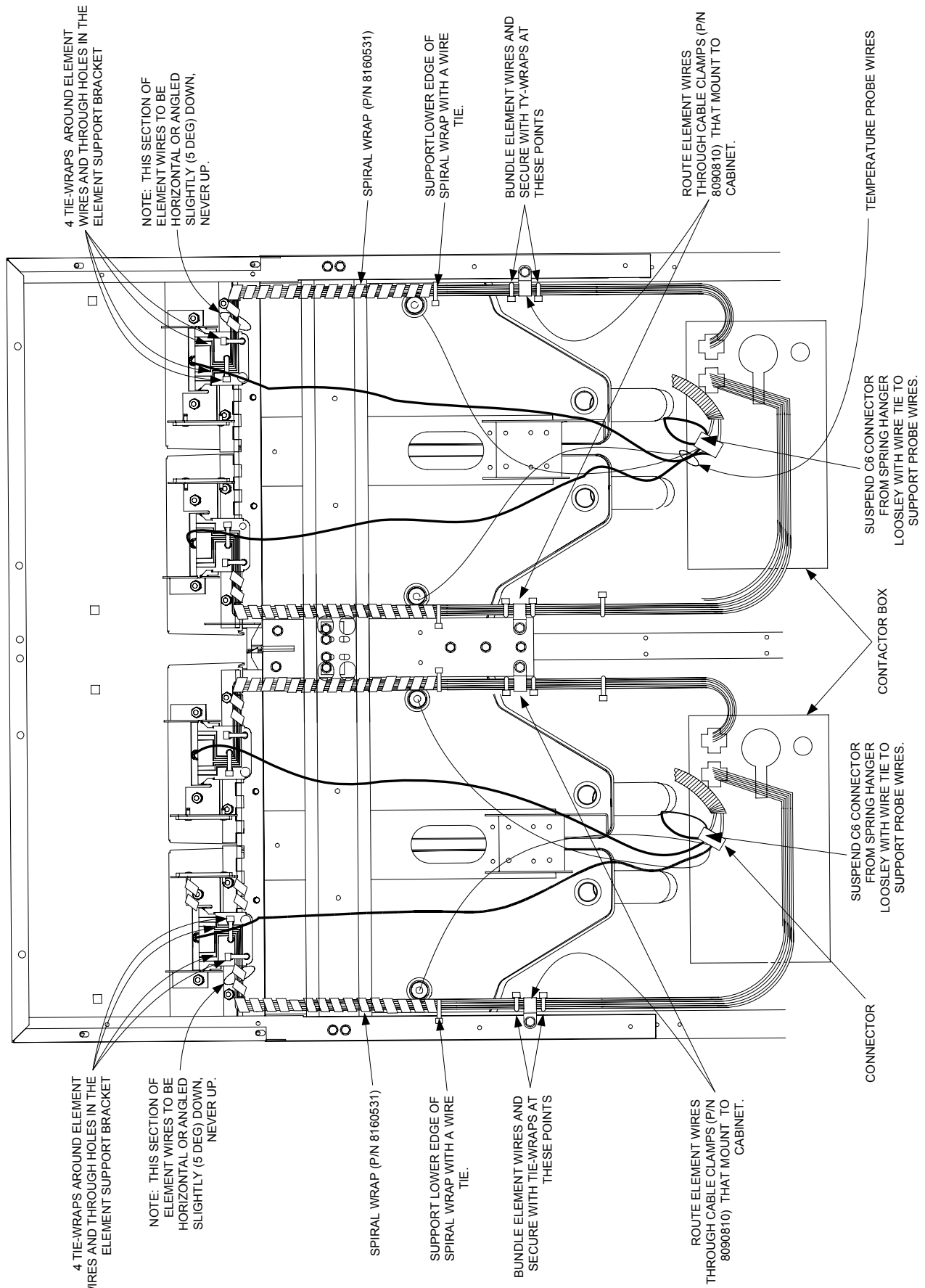

Figure 13: Suspend C6 connectors from spring hanger with a wire tie.



4 TIE-WRAPS AROUND ELEMENT WIRES AND THROUGH HOLES IN THE ELEMENT SUPPORT BRACKET

NOTE: THIS SECTION OF ELEMENT WIRES TO BE HORIZONTAL OR ANGLED SLIGHTLY (5 DEG) DOWN, NEVER UP.

SPIRAL WRAP (P/N 8160531)

SUPPORT LOWER EDGE OF SPIRAL WRAP WITH A WIRE TIE.

BUNDLE ELEMENT WIRES AND SECURE WITH TY-WRAPS AT THESE POINTS

ROUTE ELEMENT WIRES THROUGH CABLE CLAMPS (P/N 8090810) THAT MOUNT TO CABINET.

TEMPERATURE PROBE WIRES

4 TIE-WRAPS AROUND ELEMENT WIRES AND THROUGH HOLES IN THE ELEMENT SUPPORT BRACKET

NOTE: THIS SECTION OF ELEMENT WIRES TO BE HORIZONTAL OR ANGLED SLIGHTLY (5 DEG) DOWN, NEVER UP.

SPIRAL WRAP (P/N 8160531)

SUPPORT LOWER EDGE OF SPIRAL WRAP WITH A WIRE TIE.

BUNDLE ELEMENT WIRES AND SECURE WITH TY-WRAPS AT THESE POINTS

ROUTE ELEMENT WIRES THROUGH CABLE CLAMPS (P/N 8090810) THAT MOUNT TO CABINET.

SUSPEND C6 CONNECTOR FROM SPRING HANGER LOOSELY WITH WIRE TIE TO SUPPORT PROBE WIRES.

CONNECTOR BOX

SUSPEND C6 CONNECTOR FROM SPRING HANGER LOOSELY WITH WIRE TIE TO SUPPORT PROBE WIRES.

Fig. 14

ELEMENT SUPPORT BRACKET INSTALLATION INSTRUCTIONS FOR UNITS WITH TILT SWITCHES AND ELEMENT-MOUNTED HIGH LIMITS

NOTE: Fryers manufactured for sale in the European Union (CE) are equipped with tilt switches mounted on the element support bracket. World-wide, some early-production fryers have hi-limits mounted on the element support bracket. The instructions that follow address those specific configurations.

1. Dismount the tilt switch/high limit assembly from the element support bracket (see Fig. 15).
2. Remove the spring slide assemblies. Remove the element support brackets.
3. Mount the new one-piece element support bracket/spring slide assembly, and reinstall the tilt switch and high limit assembly removed in Step 1 (see Fig 16).
4. Repeat Steps 1-3 for each element assembly.
5. Return to Step 7 on Page 7 of these instructions.

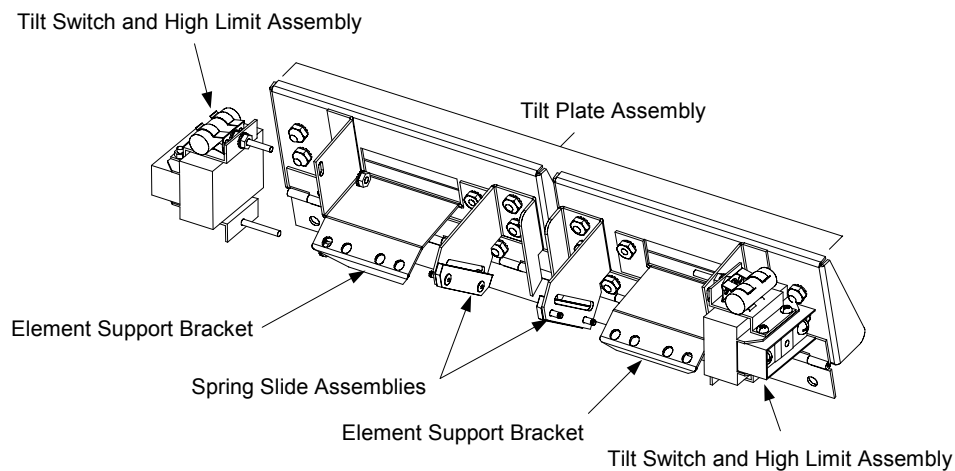

Fig 15
Step 1 - Remove Tilt Switch and High Limit Assembly

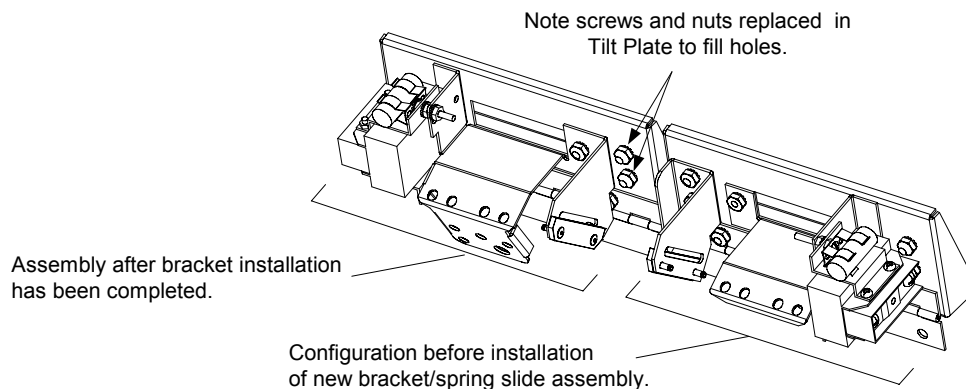

Fig. 16
Step 3 - Mount New One-Piece Element Support Bracket/Spring Slide Assembly
and Reinstall High Limit and Tilt Switch Assembly

**INSTRUCTIONS FOR INSTALLING THE REPLACEMENT
TILT SWITCH/HIGH LIMIT WIRING HARNESS**
(REQUIRED ONLY FOR UNITS HAVING A TILT SWITCH AND/OR AN ELEMENT-MOUNTED HIGH LIMIT)

To Install the Replacement Harness (806-6851SP) in a Full Vat Fryer:

1. On the new harness, use a pin pusher to remove the following wires from 15-pin connector C6: black from pin 10, white from pin 11, yellow from pin 14, and orange from pin 15.
2. Disconnect the existing harness from the contactor box.

a. If there is a tilt-switch and an element-mounted hi-limit:

- Disconnect the existing harness from the tilt switch and hi-limit and discard. Connect the blue and red wires of the replacement harness to the hi-limit (polarity does not matter).
- Connect the orange and yellow wires of the replacement harness to the tilt-switch (polarity does not matter).

b. If there is no tilt switch:

- Use a pin pusher to remove the jumper wire from Pins 8 and 9 of 15-pin connector C6 on the original harness.
- Use a pin pusher to remove the orange and yellow wires from Pins 8 & 9 of 15-pin connector C6 on the replacement harness and replace with the jumper wire removed from the original harness.
- Disconnect the existing harness from the hi-limit and discard.
- Connect the blue and red wires of the replacement harness to the hi-limit (polarity does not matter).

c. If there is no element-mounted hi-limit:

- Disconnect the existing harness from the tilt switch. Connect the orange and yellow wires of the replacement harness to the tilt switch (polarity does not matter).
 - Use a pin pusher to remove the blue and red wires from connector C6, pins 4 and 5. Discard the wires. Use a pin pusher to remove the frypot-mounted hi-limit wires from the existing harness. Insert the fry-pot mounted hi-limit wires into pins 4 and 5 of the new connector (polarity does not matter).
3. Connect the harness to the connectors on the contactor box.
 4. Test the fryers to verify correct operation.
 5. Replace back panels, position fryers under the hood and return them to service.

To Install the Replacement Harness (806-6851SP) in a Dual Vat Fryer:

1. Disconnect the existing harness from the contactor box.

a. If there are tilt switches and element-mounted hi-limits:

1. Disconnect the existing harness from both tilt switches and both hi-limits and discard.
2. Connect the blue and red wires (pins 4 and 5) of the replacement harness to the right hi-limit (polarity does not matter).
3. Connect the black and white wires (pins 10 and 11) to the left hi-limit (polarity does not matter).
4. Connect the yellow and orange wires (pins 8 and 9) to the right tilt switch (polarity does not matter).
5. Connect the yellow and orange wires (pins 14 and 15) to the left tilt switch (polarity does not matter).

b. If there are NO tilt switches:

1. Use a pin pusher to remove the jumper wires (pins 8 and 9) and (pins 14 and 15) of 15-pin connector C6 on the original harness.
2. Use a pin pusher to remove the yellow and orange wires (pins 8 and 9) and (pins 14 and 15) of connector C6 on the replacement harness and replace with the jumper wires removed from the original harness.
3. Disconnect the existing harness from both hi-limits and discard.
4. Connect the blue and red wires (pins 4 and 5) to the right hi-limit (polarity does not matter).
5. Connect the black and white wires (pins 10 and 11) to the left hi-limit (polarity does not matter).

c. If there are no element-mounted hi-limits

1. Disconnect the existing harness from the tilt switches.
 2. Connect the yellow and orange wires (pins 8 and 9) to the right tilt switch (polarity does not matter).
 3. Connect the yellow and orange wires (pins 14 and 15) to the left tilt switch (polarity does not matter).
 4. Use a pin pusher to remove the blue and red wires from connector C6 (pins 4 and 5) and the black and white wire (pins 10 and 11).
 5. Use a pin pusher to remove the frypot-mounted hi-limit wires from the existing harness.
 6. Insert the frypot-mounted right hi-limit wires into pins 4 and 5 on the new connector (polarity does not matter).
 7. Insert the left hi-limit wires into pins 10 and 11 on the new connector (polarity does not matter).
2. Connect the harness to the connectors on the contactor box.
 3. Test the fryers to verify correct operation.
 4. Replace back panels, position fryers under the hood and return them to service.

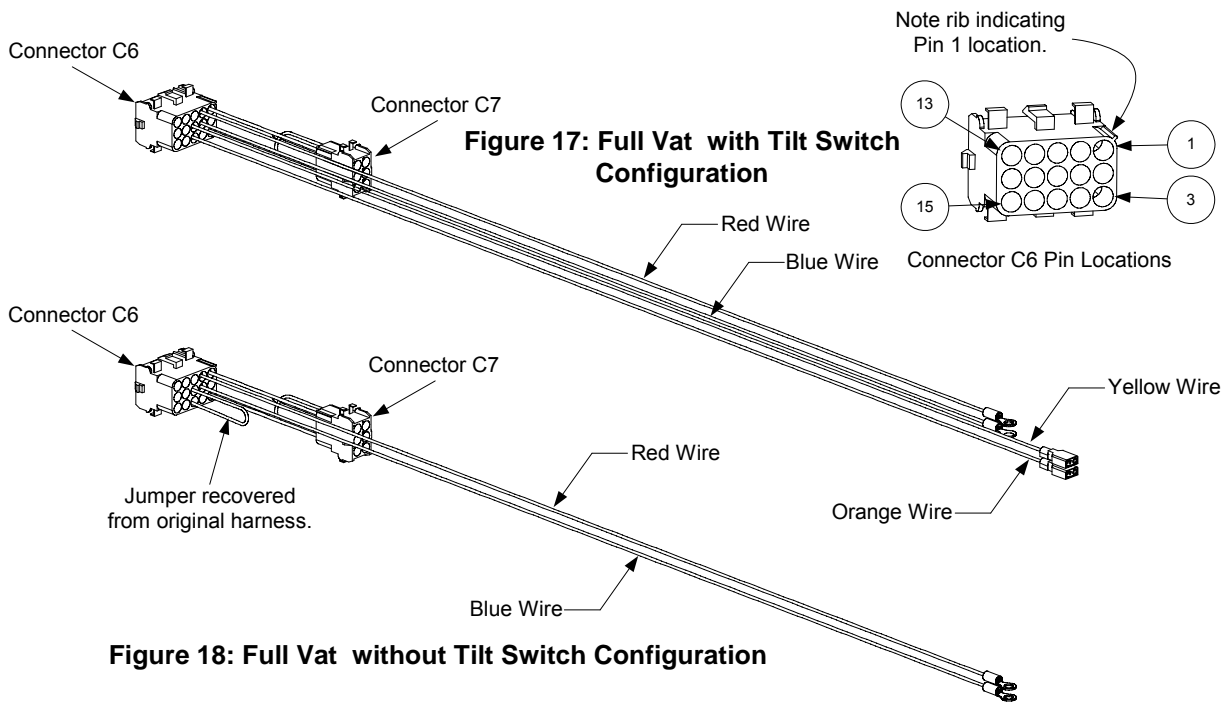

Figure 18: Full Vat without Tilt Switch Configuration

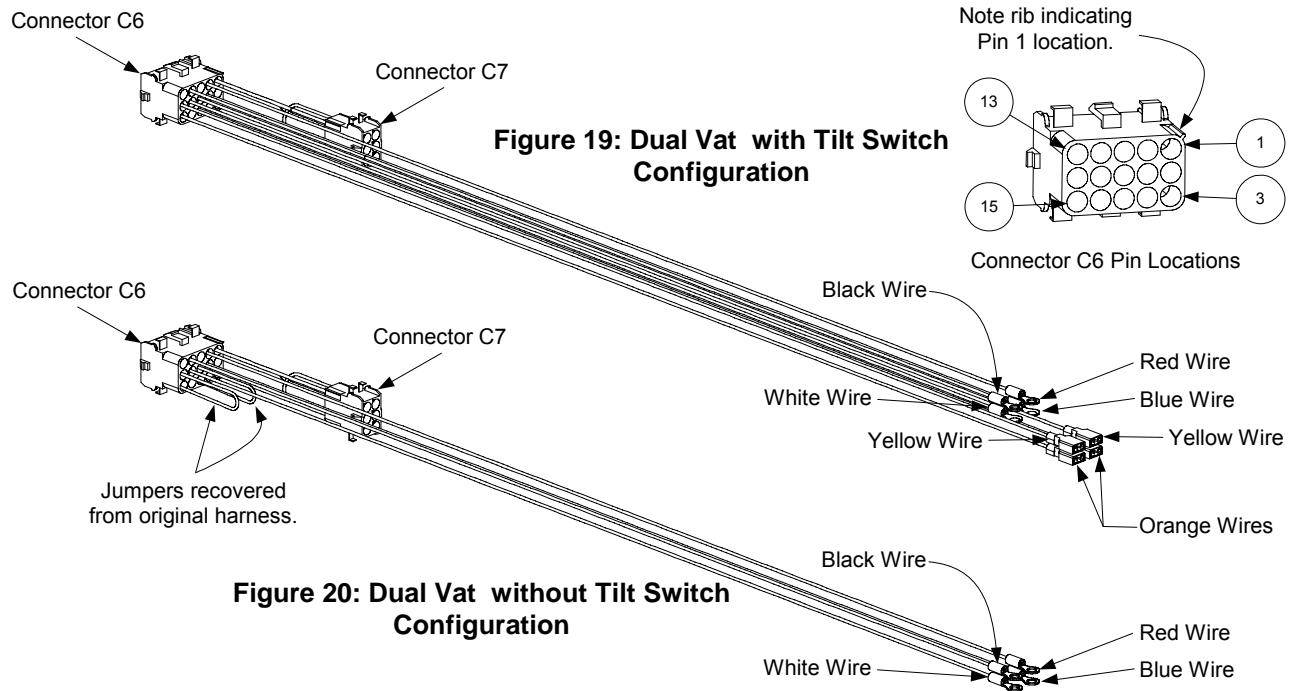

Figure 20: Dual Vat without Tilt Switch Configuration